

Intel® Open Source HD Graphics and Intel Iris™ Graphics

Programmer's Reference Manual

For the 2014–2015 Intel Core™ Processors, Celeron™ Processors
and Pentium™ Processors based on the "Broadwell" Platform

Volume 3: GPU Overview

May 2015, Revision 1.0

Creative Commons License

You are free to Share - to copy, distribute, display, and perform the work under the following conditions:

- **Attribution.** You must attribute the work in the manner specified by the author or licensor (but not in any way that suggests that they endorse you or your use of the work).
- **No Derivative Works.** You may not alter, transform, or build upon this work.

Notices and Disclaimers

INFORMATION IN THIS DOCUMENT IS PROVIDED IN CONNECTION WITH INTEL® PRODUCTS. NO LICENSE, EXPRESS OR IMPLIED, BY ESTOPPEL OR OTHERWISE, TO ANY INTELLECTUAL PROPERTY RIGHTS IS GRANTED BY THIS DOCUMENT. EXCEPT AS PROVIDED IN INTEL'S TERMS AND CONDITIONS OF SALE FOR SUCH PRODUCTS, INTEL ASSUMES NO LIABILITY WHATSOEVER AND INTEL DISCLAIMS ANY EXPRESS OR IMPLIED WARRANTY, RELATING TO SALE AND/OR USE OF INTEL PRODUCTS INCLUDING LIABILITY OR WARRANTIES RELATING TO FITNESS FOR A PARTICULAR PURPOSE, MERCHANTABILITY, OR INFRINGEMENT OF ANY PATENT, COPYRIGHT OR OTHER INTELLECTUAL PROPERTY RIGHT.

A "Mission Critical Application" is any application in which failure of the Intel Product could result, directly or indirectly, in personal injury or death. SHOULD YOU PURCHASE OR USE INTEL'S PRODUCTS FOR ANY SUCH MISSION CRITICAL APPLICATION, YOU SHALL INDEMNIFY AND HOLD INTEL AND ITS SUBSIDIARIES, SUBCONTRACTORS AND AFFILIATES, AND THE DIRECTORS, OFFICERS, AND EMPLOYEES OF EACH, HARMLESS AGAINST ALL CLAIMS COSTS, DAMAGES, AND EXPENSES AND REASONABLE ATTORNEYS' FEES ARISING OUT OF, DIRECTLY OR INDIRECTLY, ANY CLAIM OF PRODUCT LIABILITY, PERSONAL INJURY, OR DEATH ARISING IN ANY WAY OUT OF SUCH MISSION CRITICAL APPLICATION, WHETHER OR NOT INTEL OR ITS SUBCONTRACTOR WAS NEGLIGENT IN THE DESIGN, MANUFACTURE, OR WARNING OF THE INTEL PRODUCT OR ANY OF ITS PARTS.

Intel may make changes to specifications and product descriptions at any time, without notice. Designers must not rely on the absence or characteristics of any features or instructions marked "reserved" or "undefined". Intel reserves these for future definition and shall have no responsibility whatsoever for conflicts or incompatibilities arising from future changes to them. The information here is subject to change without notice. Do not finalize a design with this information.

The products described in this document may contain design defects or errors known as errata which may cause the product to deviate from published specifications. Current characterized errata are available on request.

Implementations of the I2C bus/protocol may require licenses from various entities, including Philips Electronics N.V. and North American Philips Corporation.

Intel and the Intel logo are trademarks of Intel Corporation in the U.S. and other countries.

* Other names and brands may be claimed as the property of others.

Copyright © 2015, Intel Corporation. All rights reserved.

Table of Contents

Introduction.....	1
Graphics Processing Unit (GPU)	1
GPU Overview	2
Command Stream (CS) Unit.....	3
3D Pipeline.....	3
Media Pipeline.....	3
Thread Dispatching	3
Execution Units (EUs)	3
Shared Functions.....	4
Fixed and Shared Function IDs	5
Video Codec Engine.....	6
Register Address Maps	7
Graphics Register Address Map	7
Memory and IO Space Registers.....	7
VGA and Extended VGA Register Map	8
VGA and Extended VGA I/O and Memory Register Map	8
Indirect VGA and Extended VGA Register Indices.....	9
Memory Object Overview.....	12
Hardware Status Page.....	13
Memory Access Indirection.....	13
Instruction Ring Buffers	16
Instruction Batch Buffers.....	17
Logical Contexts	18
BSD Logical Render Context Address (LRCA).....	18
Overall Context Layout	18
Register/State Context.....	19
Ring Buffer	20
Ring Context	21
The Per-Process Hardware Status Page.....	22
Copy Engine Logical Context Data [BDW].....	24
Overall Context Layout	24

Register/State Context.....	25
Ring Buffer.....	25
Ring Context.....	25
The Per-Process Hardware Status Page.....	27
Video Enhancement Logical Context Data.....	29
Overall Context Layout.....	29
Ring Context.....	29
Memory Data Formats.....	31
Unsigned Normalized (UNORM).....	31
Gamma Conversion (SRGB).....	31
Signed Normalized (SNORM).....	31
Unsigned Integer (UINT/USCALED).....	31
Signed Integer (SINT/SSCALED).....	31
Floating Point (FLOAT).....	32
64-bit Floating Point.....	32
32-bit Floating Point.....	32
16-bit Floating Point.....	33
11-bit Floating Point.....	35
10-bit Floating Point.....	35
Shared Exponent.....	36

Introduction

The integrated graphics component, specifically called the Graphics Processing Unit, or GPU, resides on the same chip die as the Central Processing Unit, or CPU, and communicates with the CPU via the on-chip bus, with internal memory and with output device(s). As Intel GPUs have evolved, they now occupy a significant percentage of space on the chip, and provide customers with high performance and low-power graphics processing, eliminating the need to purchase a separate video card for most users.

This PRM provides detailed narrative and referential information required by graphics device driver engineers and graphics API-level programmers to take advantage of the sophisticated architecture and programmability of the GPU.

Graphics Processing Unit (GPU)

The Graphics Processing Unit is controlled by the CPU through a direct interface of memory-mapped IO registers, and indirectly by parsing commands that the CPU has placed in memory. The Display interface and Blitter (**block image transferr**) are controlled primarily by direct CPU register addresses, while the 3D and Media pipelines and the parallel Video Codec Engine (VCE) are controlled primarily through instruction lists in memory.

The subsystem contains an array of cores, or execution units, with a number of “shared functions”, which receive and process messages at the request of programs running on the cores. The shared functions perform critical tasks, such as sampling textures and updating the render target (usually the frame buffer). The cores themselves are described by an instruction set architecture, or ISA.

Block Diagram of the GPU

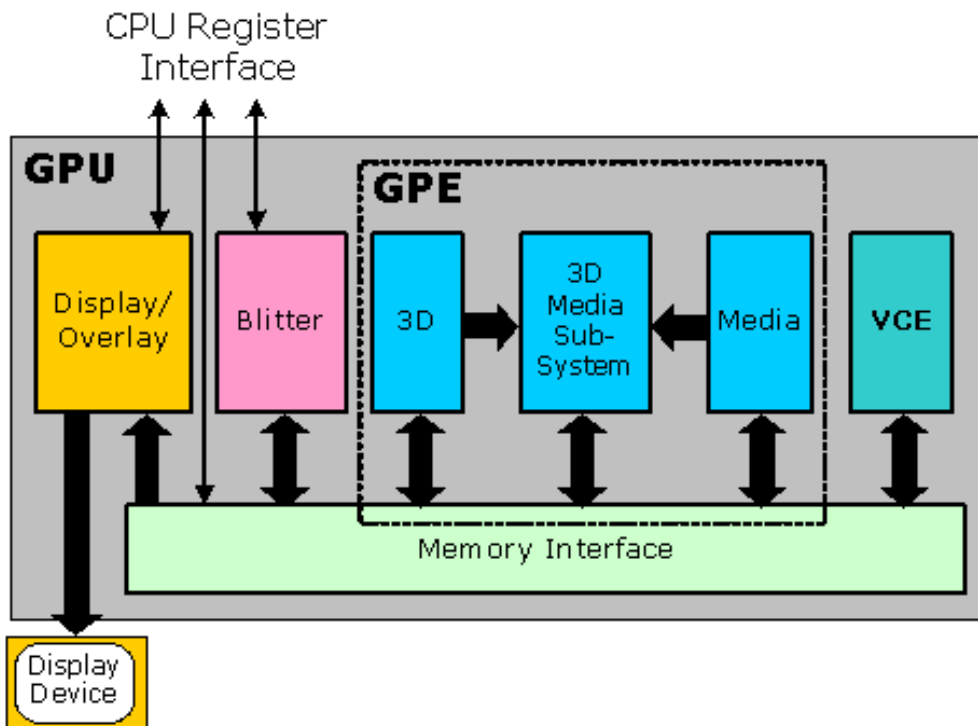

B 6675-01

GPU Overview

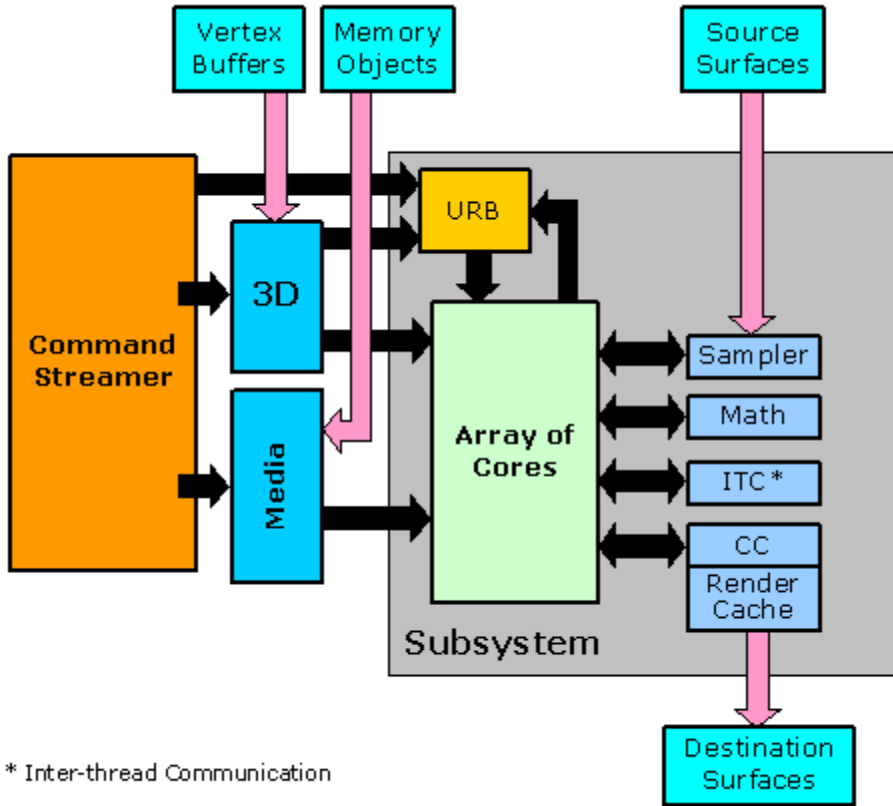

B.6676-01

The subsystem consists of an array of *execution units* (EUs, sometimes referred to as an array of *cores*) along with a set of *shared functions* outside the EUs that the EUs leverage for I/O and for complex computations. Programmers access the subsystem via the 3D or Media pipelines.

EUs are general-purpose programmable cores that support a rich instruction set that has been optimized to support various 3D API shader languages as well as media functions (primarily video) processing.

Shared functions are hardware units which serve to provide specialized supplemental functionality for the EUs. A shared function is implemented where the demand for a given specialized function is insufficient to justify the costs on a per-EU basis. Instead a single instantiation of that specialized function is implemented as a stand-alone entity outside the EUs and shared among the EUs.

Invocation of the shared functionality is performed via a communication mechanism called a *message*. A message is a small self-contained packet of information created by a kernel and directed to a specific shared function. the message is defined by a range of MRF registers that hold message operands, a destination shared function ID, a function-specific encoding of the desired operation, and a destination GRF register to which any writeback response is to be directed. Messages are dispatched to the shared function under software control via the send instruction. This instruction identifies the contents of the message and the GRF register locations to direct any response.

The message construction and delivery mechanisms are general in their definition and capable of supporting a wide variety of shared functions.

Command Stream (CS) Unit

The Command Stream (CS) unit manages the use of the 3D and Media pipelines; it performs switching between pipelines and forwarding command streams to the currently active pipeline. It manages allocation of the URB and helps support the Constant URB Entry (CURBE) function.

3D Pipeline

The 3D Pipeline provides specialized 3D primitive processing functions. These functions are provided by a pipeline of “fixed function” stages (units) and GEN threads spawned by these units. See *3D Pipeline Overview*.

Media Pipeline

The Media pipeline provides both specialized media-related processing functions and the ability to perform more general (“generic”) functionality. These Media-specific functions are provided by a Video Front End (VFE) unit. A Thread Spawner (TS) unit is utilized to spawn GEN threads requested by the VFE unit, or as required when the pipeline is used for general processing. See *Media Pipeline Overview*.

Thread Dispatching

When the 3D and Media pipelines send requests for thread initiation to the Subsystem, the thread Dispatcher receives the requests. The dispatcher performs such tasks as arbitrating between concurrent requests, assigning requested threads to hardware threads on EUs, allocating register space in each EU among multiple threads, and initializing a thread’s registers with data from the fixed functions and from the URB. This operation is largely transparent to software.

Execution Units (EUs)

The Execution Units (EUs) are the programmable shader units of the Gen Architecture. Each is a stand-alone programmable computational unit used for execution of 3D shaders and media/gpgpu kernels. Internally each is capable of multi-issue SIMD execution, and their hardware multi-threaded operation provides a very high-efficiency execution environment in the face of long data latencies typically associated with memory accesses. Each hardware thread within an EU has a dedicated large-capacity high-bandwidth register file (GRF) and associated independent thread-state. Execution is multi-issue per clock to pipelines capable of integer, single and double precision floating point operations, SIMD branch capability, logical operations, transcendental operations, and other miscellaneous operations. Communication to support units (shared functions) for operations such as texture sampling or scatter/gather load/stores is via ‘messages’ programmatically constructed and ‘sent’ to those functions, with dependency hardware causing the issuing thread to sleep until the requested data has been returned.

EU instance count varies by product generation, as well as by SKU within a given generation, and their capabilities have evolved over the many generation of the Gen Architecture.. Please see “Device

Attributes” in the “Configuration” chapter for specific rates and capacities associated with Execution Units.

Shared Functions

Shared functions are hardware units that provide specialized supplemental functionality for the EUs. A shared function is implemented where the demand for a given specialized function is insufficient to justify the costs on a per-EU basis. Instead a single instantiation of that specialized function is implemented as a stand-alone entity outside the EUs and shared among the EUs.

Invocation of the shared functionality is performed via a communication mechanism called a message. A message is a small self-contained packet of information created by a kernel and directed to a specific shared function.

Programming Note	
Context:	Communication mechanism in shared functions
The message is defined by a range of Message Register File (MRF) registers that hold message operands, a destination shared function ID, a function-specific encoding of the desired operation, and a destination General Register File (GRF) register to which any writeback response is directed.	

Messages are dispatched to the shared function under software control via the *send* instruction. This instruction identifies the contents of the message and the GRF register locations to direct any response.

The message construction and delivery mechanisms are general in their definition and capable of supporting a wide variety of shared functions.

Fixed and Shared Function IDs

The following table lists the assignments (encodings) of the Shared Function and Fixed Function IDs used within the GPE. A Shared Function is a valid target of a message initiated via a *send* instruction. A Fixed Function is an identifiable unit of the 3D or Media pipeline. Note that the Thread Spawner is both a Shared Function and Fixed Function.

Function IDs

ID[3:0]	SFID	Shared Function	FFID	Fixed Function
0x0	SFID_NULL	Null	FFID_NULL	Null
0x1	Reserved	---	Reserved	---
0x2	SFID_SAMPLER	Sampler	Reserved	---
0x3	SFID_GATEWAY	Message Gateway	Reserved	---
0x4	SFID_DP_SAMPLER	Sampler Cache Data Port	FFID_HS	Hull Shader
0x5	SFID_DP_RC	Render Cache Data Port	FFID_DS	Domain Shader
0x6	SFID_URB	URB	Reserved	---
0x7	SFID_SPAWNER	Thread Spawner	FFID_SPAWNER	Thread Spawner
0x8	SFID_VME	Video Motion Estimation	Reserved	---
0x9	SFID_DP_CC	Constant Cache Data Port	FFID_VS	Vertex Shader
0xA	SFID_DP_DC0	Data Cache Data Port0	FFID_CS	Command Stream
0xB	SFID_PI	Pixel Interpolator	FFID_VF	Vertex Fetch
0xC	SFID_DP_DC1	Data Cache Data Port1	FFID_GS	Geometry Shader
0xD	SFID_CRE	Check & Refinement Engine	Reserved	---
0xE	Reserved	---	FFID_SF	Strip/Fan Unit
0xF	Reserved	---	FFID_WM	Windower/Masker Unit

Programming Note

Context: Shared Function ID

SFID_DP_DC1 is an extension of SFID_DP_DC0 to allow for more message types. They act as a single logical entity.

Video Codec Engine

The parallel Video Codec Engine (VCE) is a fixed function video decoder and encoder engine. It is also referred to as the multi-format codec (MFX) engine, as a unified fixed function pipeline is implemented to support multiple video coding standards such as MPEG2, VC1, and AVC:

- VCS – VCE Command Streamer unit (also referred to as BCS)
- BSD – Bitstream Decoder unit
- VDS – Video Dispatcher unit
- VMC – Video Motion Compensation unit
- VIP – Video Intra Prediction unit
- VIT – Video Inverse Transform unit
- VLF – Video Loop Filter unit
- VFT – Video Forward Transform unit (encoder only)
- BSC – Bitstream Encoder unit (encoder only)

VCE Diagram

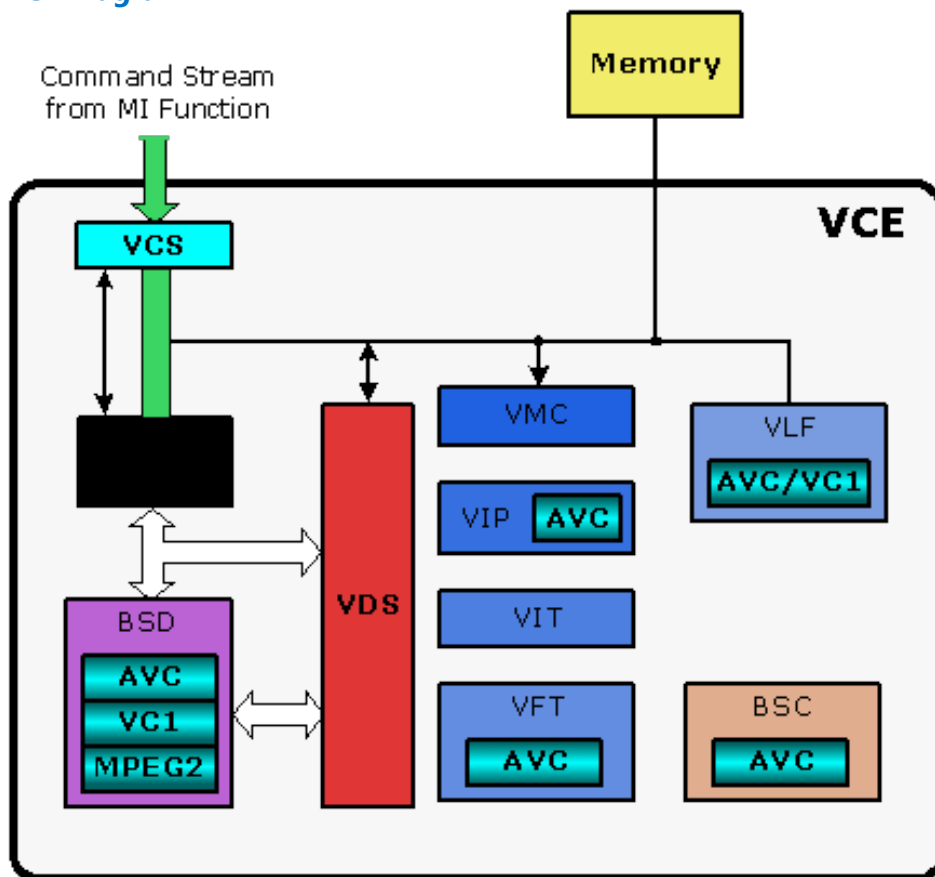

B6681-01

Device	AVC BSD	VC1 BSD	AVC Dec	VC1 Dec	MPEG2 Dec	AVC Enc
	No	No	Yes	Yes	Yes	Yes

Register Address Maps

Graphics Register Address Map

This chapter provides address maps of the graphics controllers I/O and memory-mapped registers. Individual register bit field descriptions are provided in the following chapters. PCI configuration address maps and register bit descriptions are provided in the following chapter.

Memory and IO Space Registers

These are graphics MMIO ranges used for [BDW]. Note that this is only a subset of the complete definition of the MMIO address space.

Range Start (Hex)	Range End (Hex)	Unit Owning the Range
00002000	00002FFF	Render/Generic Media Engine
00004000	00004FFF	Render/Generic Media Graphics Memory Arbiter
00012000	000123FF	MFX Control Engine (Video Command Streamer)
00012400	00012FFF	Media Units (VIN Unit)
00014000	00014FFF	MFX Memory Arbiter
00022000	00022FFF	Blitter Engine
00024000	00024FFF	Blitter Memory Arbiter
00100000	00107FFF	Fence Registers
00140000	0017FFFF	MCHBAR (SA)

Programming Note

Context:	Memory and IO space registers, graphics MMIO ranges
8800h-88FFh is a reserved range for GT. IA accesses to this region have no impact.	

VGA and Extended VGA Register Map

For I/O locations, the value in the address column represents the register I/O address. For memory mapped locations, this address is an offset from the base address programmed in the MMADR register.

VGA and Extended VGA I/O and Memory Register Map

Address	Register Name (Read)	Register Name (Write)
2D Registers		
3B0h–3B3h	Reserved	Reserved
3B4h	VGA CRTC Index (CRX) (monochrome)	VGA CRTC Index (CRX) (monochrome)
3B5h	VGA CRTC Data (monochrome)	VGA CRTC Data (monochrome)
3B6h–3B9h	Reserved	Reserved
3Bah	VGA Status Register (ST01)	VGA Feature Control Register (FCR)
3BBh–3BFh	Reserved	Reserved
3C0h	VGA Attribute Controller Index (ARX)	VGA Attribute Controller Index (ARX)/ VGA Attribute Controller Data (alternating writes select ARX or write ARxx Data)
3C1h	VGA Attribute Controller Data (read ARxx data)	Reserved
3C2h	VGA Feature Read Register (ST00)	VGA Miscellaneous Output Register (MSR)
3C3h	Reserved	Reserved
3C4h	VGA Sequencer Index (SRX)	VGA Sequencer Index (SRX)
3C5h	VGA Sequencer Data (SRxx)	VGA Sequencer Data (SRxx)
3C6h	VGA Color Palette Mask (DACMASK)	VGA Color Palette Mask (DACMASK)
3C7h	VGA Color Palette State (DACSTATE)	VGA Color Palette Read Mode Index (DACRX)
3C8h	VGA Color Palette Write Mode Index (DACWX)	VGA Color Palette Write Mode Index (DACWX)
3C9h	VGA Color Palette Data (DACDATA)	VGA Color Palette Data (DACDATA)
3CAh	VGA Feature Control Register (FCR)	Reserved
3CBh	Reserved	Reserved
3CCh	VGA Miscellaneous Output Register (MSR)	Reserved
3CDh	Reserved	Reserved
3CEh	VGA Graphics Controller Index (GRX)	VGA Graphics Controller Index (GRX)
3CFh	VGA Graphics Controller Data (GRxx)	VGA Graphics Controller Data (GRxx)
3D0h–3D1h	Reserved	Reserved
2D Registers		
3D4h	VGA CRTC Index (CRX)	VGA CRTC Index (CRX)
3D5h	VGA CRTC Data (CRxx)	VGA CRTC Data (CRxx)

Address	Register Name (Read)	Register Name (Write)
System Configuration Registers		
3D6h	GFX/2D Configurations Extensions Index (XRX)	GFX/2D Configurations Extensions Index (XRX)
3D7h	GFX/2D Configurations Extensions Data (XRxx)	GFX/2D Configurations Extensions Data (XRxx)
2D Registers		
3D8h–3D9h	Reserved	Reserved
3DAh	VGA Status Register (ST01)	VGA Feature Control Register (FCR)
3DBh–3DFh	Reserved	Reserved

Indirect VGA and Extended VGA Register Indices

The registers listed in this section are indirectly accessed by programming an index value into the appropriate SRX, GRX, ARX, or CRX register. The index and data register address locations are listed in the previous section. Additional details concerning the indirect access mechanism are provided in the *VGA and Extended VGA Register Description* Chapter (see SRxx, GRxx, ARxx or CRxx sections).

2D Sequence Registers (3C4h / 3C5h)

Index	Sym	Description
00h	SR00	Sequencer Reset
01h	SR01	Clocking Mode
02h	SR02	Plane / Map Mask
03h	SR03	Character Font
04h	SR04	Memory Mode
07h	SR07	Horizontal Character Counter Reset

2D Graphics Controller Registers (3CEh / 3CFh)

Index	Sym	Register Name
00h	GR00	Set / Reset
01h	GR01	Enable Set / Reset
02h	GR02	Color Compare
03h	GR03	Data Rotate
04h	GR04	Read Plane Select
05h	GR05	Graphics Mode
06h	GR06	Miscellaneous
07h	GR07	Color Don't Care
08h	GR08	Bit Mask
10h	GR10	Address Mapping
11h	GR11	Page Selector
18h	GR18	Software Flags

2D Attribute Controller Registers (3C0h / 3C1h)

Index	Sym	Register Name
00h	AR00	Palette Register 0
01h	AR01	Palette Register 1
02h	AR02	Palette Register 2
03h	AR03	Palette Register 3
04h	AR04	Palette Register 4
05h	AR05	Palette Register 5
06h	AR06	Palette Register 6
07h	AR07	Palette Register 7
08h	AR08	Palette Register 8
09h	AR09	Palette Register 9
0Ah	AR0A	Palette Register A
0Bh	AR0B	Palette Register B
0Ch	AR0C	Palette Register C
0Dh	AR0D	Palette Register D
0Eh	AR0E	Palette Register E
0Fh	AR0F	Palette Register F
10h	AR10	Mode Control
11h	AR11	Overscan Color
12h	AR12	Memory Plane Enable
13h	AR13	Horizontal Pixel Panning
14h	AR14	Color Select

2D CRT Controller Registers (3B4h / 3D4h / 3B5h / 3D5h)

Index	Sym	Register Name
00h	CR00	Horizontal Total
01h	CR01	Horizontal Display Enable End
02h	CR02	Horizontal Blanking Start
03h	CR03	Horizontal Blanking End
04h	CR04	Horizontal Sync Start
05h	CR05	Horizontal Sync End
06h	CR06	Vertical Total
07h	CR07	Overflow
08h	CR08	Preset Row Scan
09h	CR09	Maximum Scan Line
0Ah	CR0A	Text Cursor Start
0Bh	CR0B	Text Cursor End
0Ch	CR0C	Start Address High
0Dh	CR0D	Start Address Low
0Eh	CR0E	Text Cursor Location High
0Fh	CR0F	Text Cursor Location Low
10h	CR10	Vertical Sync Start
11h	CR11	Vertical Sync End
12h	CR12	Vertical Display Enable End
13h	CR13	Offset
14h	CR14	Underline Location
15h	CR15	Vertical Blanking Start
16h	CR16	Vertical Blanking End
17h	CR17	CRT Mode
18h	CR18	Line Compare
22h	CR22	Memory Read Latch Data

Memory Object Overview

Any memory data accessed by the device is considered part of a *memory object* of some memory object type.

The following table lists the various memory objects types and an indication of their role in the system.

Memory Object Type	Role
Graphics Translation Table (GTT)	Contains PTEs used to translate "graphics addresses" into physical memory addresses.
Hardware Status Page	Cached page of system memory used to provide fast driver synchronization.
Logical Context Buffer	Memory areas used to store (save/restore) images of hardware rendering contexts. Logical contexts are referenced via a pointer to the corresponding Logical Context Buffer.
Ring Buffers	Buffers used to transfer (DMA) instruction data to the device. Primary means of controlling rendering operations.
Batch Buffers	Buffers of instructions invoked indirectly from Ring Buffers.
State Descriptors	Contains state information in a prescribed layout format to be read by hardware. Many different state descriptor formats are supported.
Vertex Buffers	Buffers of 3D vertex data indirectly referenced through "indexed" 3D primitive instructions.
VGA Buffer (Must be mapped UC on PCI)	Graphics memory buffer used to drive the display output while in legacy VGA mode.
Display Surface	Memory buffer used to display images on display devices.
Overlay Surface	Memory buffer used to display overlaid images on display devices.
Overlay Register, Filter Coefficients	Memory area used to provide double-buffer for Overlay register and filter coefficient loading.
Cursor Surface	Hardware cursor pattern in memory.
2D Render Source	Surface used as primary input to 2D rendering operations.
2D Render R-M-W Destination	2D rendering output surface that is read in order to be combined in the rendering function. Destination surfaces that accessed via this Read-Modify-Write mode have somewhat different restrictions than Write-Only Destination surfaces.
2D Render Write-Only Destination	2D rendering output surface that is written but not read by the 2D rendering function. Destination surfaces that accessed via a Write-Only mode have somewhat different restrictions than Read-Modify-Write Destination surfaces.
2D Monochrome Source	1 bpp surfaces used as inputs to 2D rendering after being converted to foreground/background colors.
2D Color Pattern	8x8 pixel array used to supply the "pattern" input to 2D rendering functions.
DIB	"Device Independent Bitmap" surface containing "logical" pixel values that are converted (via LUTs) to physical colors.
3D Color Buffer	Surface receiving color output of 3D rendering operations. May also be accessed via R-M-W (aka blending). Also referred to as a Render Target.

Memory Object Type	Role
3D Depth Buffer	Surface used to hold per-pixel depth and stencil values used in 3D rendering operations. Accessed via RMW.
3D Texture Map	Color surface (or collection of surfaces) which provide texture data in 3D rendering operations.
"Non-3D" Texture	Surface read by Texture Samplers, though not in normal 3D rendering operations (for example, in video color conversion functions).
Motion Comp Surfaces	These are the Motion Comp reference pictures.
Motion Comp Correction Data Buffer	This is Motion Comp intra-coded or inter-coded correction data.

Hardware Status Page

The hardware status page is a naturally-aligned 4KB page residing in snooped system memory. This page exists primarily to allow the device to report status via PCI master writes – thereby allowing the driver to read/poll WB memory instead of UC reads of device registers or UC memory.

The address of this page is programmed via the HWS_PGA MI register. The definition of that register (in *Memory Interface Registers*) includes a description of the layout of the Hardware Status Page.

Memory Access Indirection

The GPE supports the indirection of certain graphics (GTT-mapped) memory accesses. This support comes in the form of two *base address* state variables used in certain memory address computations with the GPE.

The intent of this functionality is to support the dynamic relocation of certain driver-generated memory structures after command buffers have been generated but prior to their submittal for execution. For example, as the driver builds the command stream it could append pipeline state descriptors, kernel binaries, etc. to a general state buffer. References to the individual items would be inserted in the command buffers as offsets from the base address of the state buffer. The state buffer could then be freely relocated prior to command buffer execution, with the driver only needing to specify the final base address of the state buffer. Two base addresses are provided to permit surface-related state (binding tables, surface state tables) to be maintained in a state buffer separate from the general state buffer.

While the use of these base addresses is unconditional, the indirection can be effectively disabled by setting the base addresses to zero. The following table lists the various GPE memory access paths and which base address (if any) is relevant.

Base Address Utilization

Base Address Used	Memory Accesses
General State Base Address	DataPort Read/Write DataPort memory accesses resulting from 'stateless' DataPort Read/Write requests. See <i>DataPort</i> for a definition of the 'stateless' form of requests.
Dynamic State Base Address	Sampler reads of SAMPLER_STATE data and associated SAMPLER_BORDER_COLOR_STATE.
	Viewport states used by CLIP, SF, and WM/CC
	COLOR_CALC_STATE, DEPTH_STENCIL_STATE, and BLEND_STATE
Instruction Base Address	<p>Normal EU instruction stream (non-system routine)</p> <p>System routine EU instruction stream (starting address = SIP)</p>
Surface State Base Address	Sampler and DataPort reads of BINDING_TABLE_STATE, as referenced by BT pointers passed via 3DSTATE_BINDING_TABLE_POINTERS
	Sampler and DataPort reads of SURFACE_STATE data
Indirect Object Base Address	MEDIA_OBJECT Indirect Data accessed by the CS unit .
None	CS unit reads from Ring Buffers, Batch Buffers
	CS writes resulting from PIPE_CONTROL command
	All VF unit memory accesses (Index Buffers, Vertex Buffers)
	All Sampler Surface Memory Data accesses (texture fetch, etc.)
	All DataPort memory accesses except 'stateless' DataPort Read/Write requests (e.g., RT accesses.) See <i>DataPort</i> for a definition of the 'stateless' form of requests.
	Memory reads resulting from STATE_PREFETCH commands
	Any physical memory access by the device
	GTT-mapped accesses not included above (i.e., default)
	[BDW]: Push Constants (depending on state of INSTPM<CONSTANT_BUFFER Address Offset Disable>)

The following notation is used in the PRM to distinguish between addresses and offsets:

Notation	Definition
PhysicalAddress[n:m]	Corresponding bits of a physical graphics memory byte address (not mapped by a GTT)
GraphicsAddress[n:m]	Corresponding bits of an absolute, virtual graphics memory byte address (mapped by a GTT)
GeneralStateOffset[n:m]	Corresponding bits of a relative byte offset added to the General State Base Address value, the result of which is interpreted as a virtual graphics memory byte address (mapped by a GTT)
DynamicStateOffset[n:m]	Corresponding bits of a relative byte offset added to the Dynamic State Base Address value, the result of which is interpreted as a virtual graphics memory byte address (mapped by a GTT)
InstructionBaseOffset[n:m]	Corresponding bits of a relative byte offset added to the Instruction Base Address value, the result of which is interpreted as a virtual graphics memory byte address (mapped by a GTT)
SurfaceStateOffset[n:m]	Corresponding bits of a relative byte offset added to the Surface State Base Address value, the result of which is interpreted as a virtual graphics memory byte address (mapped by a GTT)

Instruction Ring Buffers

Instruction ring buffers are the memory areas used to pass instructions to the device. Refer to the Programming Interface chapter for a description of how these buffers are used to transport instructions.

The RINGBUF register sets (defined in Memory Interface Registers) are used to specify the ring buffer memory areas. The ring buffer must start on a 4KB boundary and be allocated in linear memory. The length of any one ring buffer is limited to 2MB.

Programming Note	
Context:	Instruction Ring Buffers in memory areas.
"Indirect" 3D primitive instructions (those that access vertex buffers) must reside in the same memory space as the vertex buffers.	

Instruction Batch Buffers

Instruction batch buffers are contiguous streams of instructions referenced via an MI_BATCH_BUFFER_START and related instructions (see Memory Interface Instructions, Programming Interface). They are used to transport instructions external to ring buffers.

Programming Note	
Context:	Instruction batch buffers in memory objects
Batch buffers should not be mapped to snooped SM (PCI) addresses. The device will treat these as MainMemory (MM) addresses and, therefore, not snoop the CPU cache.	

Programming Note	
Context:	Instruction batch buffers in memory objects
The batch buffer must be QWord aligned and a multiple of QWords in length. The ending address is the address of the last valid QWord in the buffer. The length of any single batch buffer is "virtually unlimited" (i.e., could theoretically be 4GB in length).	

Logical Contexts

This section includes the following subsections:

- [BSD Logical Render Context Address \(LRCA\)](#)
- [Video Enhancement Logical Context Data](#)

BSD Logical Render Context Address (LRCA)

This section discusses the following topics for the BSD Logical Render Context Address (LRCA):

- Overall Context Layout
- Register State Context
- Ring Buffer [BDW]
- Ring Context [BDW]
- The Per-Process Hardware Status Page

Overall Context Layout

When Execlists are enabled, the Context Image for the media engine consists of two 4K pages:

Per-Process HW Status Page (4K)
Register State Context

When Execlists are disabled (ring buffer mode of scheduling) there is no concept of context for workloads submitted to media engine and hence there is no context image.

Register State context is explained in detail in "Register State Context" Section.

Register/State Context

Note: The Register/State Context is valid only when Execlists and PPGTT are enabled.

DW Range	DW Count	State Field	Restore Inhibited	PPGTT and Execlists Enabled	PPGTT and Execlists Disabled	Power Context	Set Before Submitting Context?
00h	1	Context Control	R	S/R	X	S/R	Yes
01h	1	Ring Head Pointer Register	R	S/R	X	S/R	Yes
02h	1	Ring Tail Pointer Register	R	R	X	S/R	Yes
03h	1	Batch Buffer Current Head Register	NR	S/R	X	S/R	No
04h	1	Batch Buffer State Register	NR	S/R	X	S/R	No
05h	1	PPGTT Directory Cache Valid Register (Software always populates via host)	R	R	X	S/R	Yes
06h	1	Reserved	X	X	X	S/R	X
07h	1	PD Base Virtual Address Register	R	R	X	S/R	Yes
08h	1	MF_X_STATE_POINTER 0	NR	S/R	X	S/R	Yes
09h	1	MF_X_STATE_POINTER 1	NR	S/R	X	S/R	Yes
0Ah	1	MF_X_STATE_POINTER 2	NR	S/R	X	S/R	Yes
0Bh	1	MF_X_STATE_POINTER 3	NR	S/R	X	S/R	Yes
0Ch	1	VCS_CNTR — Media Watchdog Counter Control	NR	S/R	X	S/R	No
0Dh	1	VCS_THRSH — Media Watchdog Counter Threshold	NR	S/R	X	S/R	No
0Eh	1	Current Context ID Register	NR	S/R	X	S/R	No
0Fh	1	Reserved	X	X	X	S/R	X

Ring Buffer

Ring Buffer can exist anywhere in memory mapped via Global GTT. Ring buffer details are mentioned in the ring context area of LRCA (Ring Buffer - Start Address, Head Offset, Tail Pointer & Control Register) in the Execution List mode of scheduling.

Programming Note	
Context:	Ring buffers - ring context area of LRCA
Ring Buffer registers are directly programmed in the Ring Buffer mode of scheduling.	

Ring Context

Ring Context starts at 4K offset from LRCA. Ring context contains all the details that are needed to be initialized by SW for submitting a context to HW for execution (Ring Buffer Details, Page Directory Information, etc). Ring context is five cachelines in size.

Programming Note	
Context:	Submitting a context to HW for execution.
The last cacheline of the ring context is specific for a given Engine and hence SW needs to populate it accordingly.	

Description	MMIO Offset/Command		# of DW
NOOP		VCS	1
Load_Register_Immediate header	0x1100_1015	VCS	1
Context Control	0x12244	VCS	2
Ring Head Pointer Register	0x12034	VCS	2
Ring Tail Pointer Register	0x12030	VCS	2
RING_BUFFER_START	0x12038	VCS	2
RING_BUFFER_CONTROL	0x1203C	VCS	2
Batch Buffer Current Head Register (UDW)	0x12168	VCS	2
Batch Buffer Current Head Register	0x12140	VCS	2
Batch Buffer State Register	0x12110	VCS	2
SECOND_BB_ADDR_UDW	0x1211C	VCS	2
SECOND_BB_ADDR	0x12114	VCS	2
SECOND_BB_STATE	0x12118	VCS	2
NOOP		VCS	8
NOOP		VCS	1
Load_Register_Immediate header	0x1100_1011	VCS	1
CTX_TIMESTAMP	0x123A8	VCS	2
PDP3_UDW	0x1228C	VCS	2
PDP3_LDW	0x 12288	VCS	2
PDP2_UDW	0x 12284	VCS	2
PDP2_LDW	0x 12280	VCS	2
PDP1_UDW	0x 1227C	VCS	2
PDP1_LDW	0x 12278	VCS	2
PDP0_UDW	0x 12274	VCS	2
PDP0_LDW	0x 12270	VCS	2
NOOP		VCS	12
NOOP		VCS	16

The Per-Process Hardware Status Page

The following table defines the layout of the Per-Process Hardware Status Page.

The DWord offset values in the table are in hexadecimal.

DWord Offset	Description						
(3FFh – 020h)	These locations can be used for general purpose via the MI_STORE_DATA_INDEX or MI_STORE_DATA_IMM instructions.						
1F:1C	Reserved.						
1B:18	MI_SEMAPHORE_WAIT. MI_SEMAPHORE_WAIT command on which the context got switched out due to semaphore wait. This field is only valid and must be looked at when the context switch reason in context status buffer is stated as “Wait on Semaphore”.						
17:16	Context Save Finished Timestamp. TIMESTAMP register sampled on context save completion is reported.						
15:14	Context Restore Complete Timestamp. TIMESTAMP register sampled on context restore complete is reported.						
13:12	Preempt Request Received Timestamp. TIMESTAMP register sampled on preemption request is reported.						
11	<table border="1"> <thead> <tr> <th>Bits</th> <th>Description</th> </tr> </thead> <tbody> <tr> <td>31:2</td> <td>Reserved Format: MBZ Must be set to modify corresponding bit in Bits 15:0. (All implemented bits)</td> </tr> <tr> <td>1</td> <td>Reserved Format: MBZ Must be set to modify corresponding bit in Bits 15:0. (All implemented bits)</td> </tr> </tbody> </table>	Bits	Description	31:2	Reserved Format: MBZ Must be set to modify corresponding bit in Bits 15:0. (All implemented bits)	1	Reserved Format: MBZ Must be set to modify corresponding bit in Bits 15:0. (All implemented bits)
	Bits	Description					
	31:2	Reserved Format: MBZ Must be set to modify corresponding bit in Bits 15:0. (All implemented bits)					
1	Reserved Format: MBZ Must be set to modify corresponding bit in Bits 15:0. (All implemented bits)						
10	Cumulative Context Run Time. This has the cumulative run time of the context on HW. HW reports CTX_TIMESTAMP to this location on a context switch.						
F:5	Reserved.						
4	Ring Head Pointer Storage. The contents of the Ring Buffer Head Pointer register (register DWord 1) are written to this location either as result of an MI_REPORT_HEAD instruction or as the result of an “automatic report” (see RINGBUF registers).						
3:0	Reserved.						

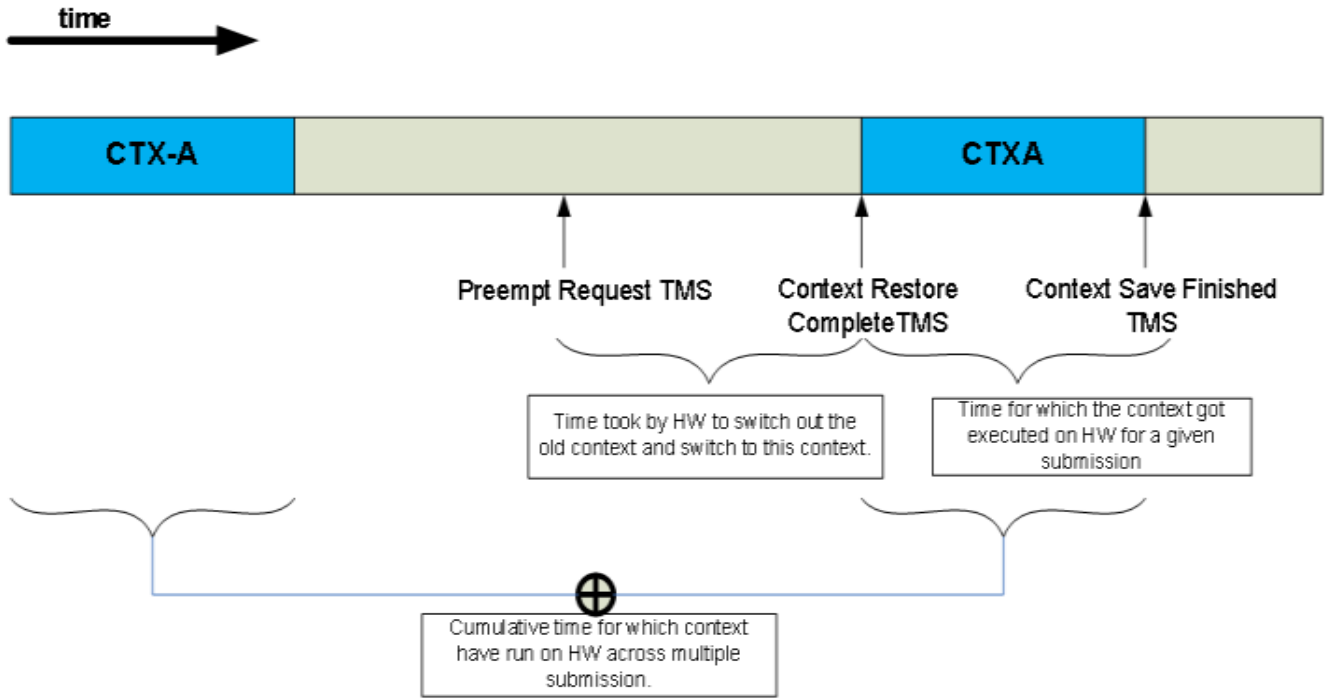

This page is designed to be read by SW to glean additional details about a context beyond what it can get from the context status.

Accesses to this page are automatically treated as cacheable and snooped. It is therefore illegal to locate this page in any region where snooping is illegal (such as in stolen memory).

Copy Engine Logical Context Data [BDW]

Overall Context Layout

When Execlists are enabled, the Context Image for the copy engine consists of two 4K pages:

- Per-Process HW Status Page (4K)
- Register State Context
- When Execlists are disabled (ring buffer mode of scheduling) there is no concept of context for workloads submitted to media engine and hence there is no context image.

Register/State Context

Ring Buffer

Ring Buffer can exist anywhere in memory mapped via Global GTT. Ring buffer details are mentioned in the ring context area of LRCA (Ring Buffer - Start Address, Head Offset, Tail Pointer & Control Register) in Execution List mode of scheduling. Ring Buffer registers are directly programmed in Ring Buffer mode of scheduling.

Ring Context

Ring Context starts at 4K offset from LRCA. Ring context contains all the details that are needed to be initialized by SW for submitting a context to HW for execution (Ring Buffer Details, Page Directory Information, etc). Ring context is five cachelines in size.

Programming Note	
Context:	Submitting a context to HW for execution
The last cacheline of the ring context is specific for a given Engine and hence SW needs to populate it accordingly.	

Description			# of DW
NOOP		BCS	1
Load_Register_Immediate header	0x1100_1015	BCS	1
Context Control	0x22244	BCS	2
Ring Head Pointer Register	0x22034	BCS	2
Ring Tail Pointer Register	0x22030	BCS	2
RING_BUFFER_START	0x22038	BCS	2
RING_BUFFER_CONTROL	0x2203C	BCS	2
Batch Buffer Current Head Register	0x22140	BCS	4
Batch Buffer State Register	0x22110	BCS	2
SECOND_BB_ADDR	0x22114	BCS	4
SECOND_BB_STATE	0x22118	BCS	2
NOOP		BCS	8
NOOP		BCS	1
Load_Register_Immediate header	0x1100_100F	BCS	1
CTX_TIMESTAMP	0x223A8	BCS	2
PDP3_UDW	0x 2228C	BCS	2
PDP3_LDW	0x 22288	BCS	2
PDP2_UDW	0x 22284	BCS	2
PDP2_LDW	0x 22280	BCS	2
PDP1_UDW	0x 2227C	BCS	2
PDP1_LDW	0x 22278	BCS	2

Description			# of DW
PDP0_UDW	0x 22274	BCS	2
PDP0_LDW	0x 22270	BCS	2
NOOP		BCS	12
NOOP		BCS	1
Load_Register_Immediate header	0x1100_1001	BCS	1
BCS_BTILEY	0x22200	BCS	2
NOOP		BCS	12

The Per-Process Hardware Status Page

The following table defines the layout of the Per-Process Hardware Status Page.

The DWord offset values in the table are in hexadecimal.

DWord Offset	Description						
(3FFh – 020h)	These locations can be used for general purpose via the MI_STORE_DATA_INDEX or MI_STORE_DATA_IMM instructions.						
1F:1C	Reserved.						
1B:18	MI_SEMAPHORE_WAIT. MI_SEMAPHORE_WAIT command on which the context got switched out due to semaphore wait. This field is only valid and must be looked at when the context switch reason in context status buffer is stated as “Wait on Semaphore”.						
17:16	Context Save Finished Timestamp. TIMESTAMP register sampled on context save completion is reported.						
15:14	Context Restore Complete Timestamp. TIMESTAMP register sampled on context restore complete is reported.						
13:12	Preempt Request Received Timestamp. TIMESTAMP register sampled on preemption request is reported.						
11	<table border="1"> <thead> <tr> <th>Bits</th> <th>Description</th> </tr> </thead> <tbody> <tr> <td>31:2</td> <td>Reserved Format: MBZ Must be set to modify corresponding bit in Bits 15:0. (All implemented bits)</td> </tr> <tr> <td>1</td> <td>Reserved Format: MBZ Must be set to modify corresponding bit in Bits 15:0. (All implemented bits)</td> </tr> </tbody> </table>	Bits	Description	31:2	Reserved Format: MBZ Must be set to modify corresponding bit in Bits 15:0. (All implemented bits)	1	Reserved Format: MBZ Must be set to modify corresponding bit in Bits 15:0. (All implemented bits)
	Bits	Description					
	31:2	Reserved Format: MBZ Must be set to modify corresponding bit in Bits 15:0. (All implemented bits)					
1	Reserved Format: MBZ Must be set to modify corresponding bit in Bits 15:0. (All implemented bits)						
10	Cumulative Context Run Time. This has the cumulative run time of the context on HW. HW reports CTX_TIMESTAMP to this location on a context switch.						
F:5	Reserved.						
4	Ring Head Pointer Storage. The contents of the Ring Buffer Head Pointer register (register DWord 1) are written to this location either as result of an MI_REPORT_HEAD instruction or as the result of an “automatic report” (see RINGBUF registers).						
3:0	Reserved.						

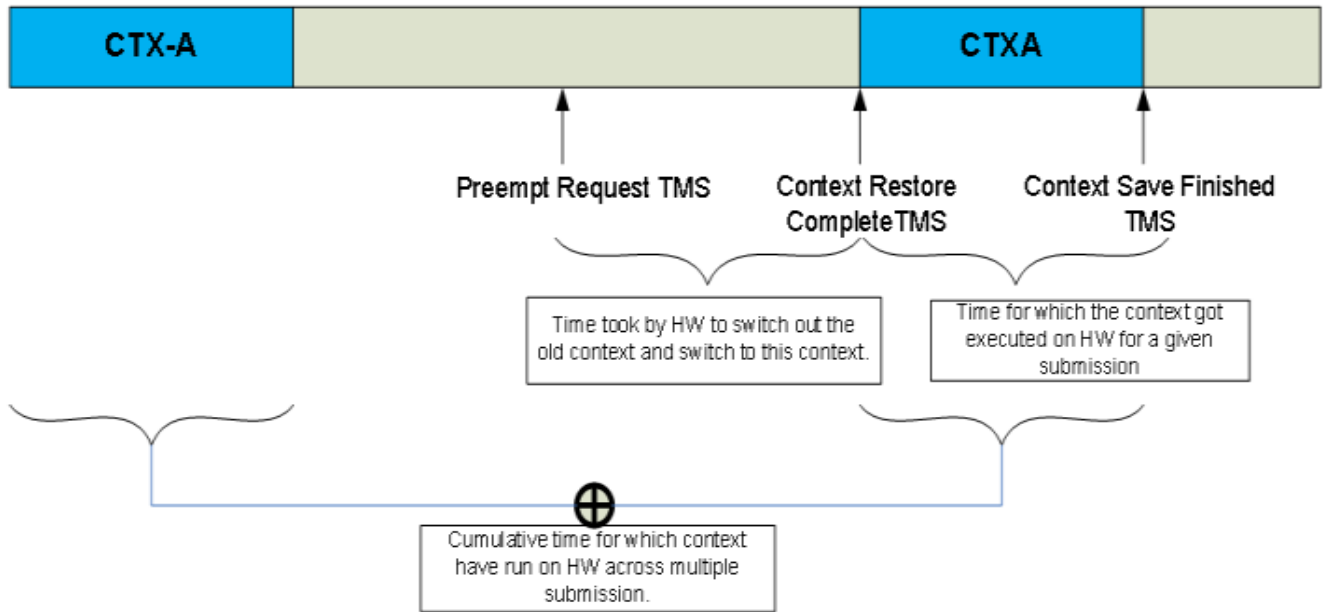

This page is designed to be read by SW to glean additional details about a context beyond what it can get from the context status.

Accesses to this page are automatically treated as cacheable and snooped. It is therefore illegal to locate this page in any region where snooping is illegal (such as in stolen memory).

Video Enhancement Logical Context Data

This section discusses the following topics for the Video Enhancement Logical Context Data:

- Overall Context Layout
- Ring Context [BDW]

Overall Context Layout

When Execlists are enabled, the Context Image for the Video Enhancement engine consists of two 4K pages:

Per-Process HW Status Page (4K)
Register State Context
When Execlists are disabled (ring buffer mode of scheduling) there is no concept of context for workloads submitted to media engine and hence there is no context image.

Register State context is explained in detail in “Register State Context” section.

Ring Context

Ring Context starts at 4K offset from LRCA. Ring context contains all the details that are needed to be initialized by SW for submitting a context to HW for execution (Ring Buffer Details, Page Directory Information ..etc). Ring context is five cachelines in size.

Programming Note	
Context:	Submitting a context to HW for execution
The last cacheline of the ring context is specific for a given Engine and hence SW needs to populate it accordingly.	

Description			# of DW
NOOP		VECS	1
Load_Register_Immediate header	0x1100_1015	VECS	1
Context Control	0x1A244	VECS	2
Ring Head Pointer Register	0x1A034	VECS	2
Ring Tail Pointer Register	0x1A030	VECS	2
RING_BUFFER_START	0x1A038	VECS	2
RING_BUFFER_CONTROL	0x1A03C	VECS	2
Batch Buffer Current Head Register	0x1A140	VECS	4
Batch Buffer State Register	0x1A110	VECS	2
SECOND_BB_ADDR	0x1A114	VECS	4
SECOND_BB_STATE	0x1A118	VECS	2
NOOP		VECS	8
NOOP		VECS	1

Description			# of DW
Load_Register_Immediate header	0x1100_100F	VECS	1
CTX_TIMESTAMP	0x1A3A8	VECS	2
PDP3_UDW	0x 1A28C	VECS	2
PDP3_LDW	0x 1A288	VECS	2
PDP2_UDW	0x 1A284	VECS	2
PDP2_LDW	0x 1A280	VECS	2
PDP1_UDW	0x 1A27C	VECS	2
PDP1_LDW	0x 1A278	VECS	2
PDP0_UDW	0x 1A274	VECS	2
PDP0_LDW	0x 1A270	VECS	2
NOOP		VECS	12
NOOP		VECS	16

Memory Data Formats

This chapter describes the attributes associated with the memory-resident data objects operated on by the graphics pipeline. This includes object types, pixel formats, memory layouts, and rules/restrictions placed on the dimensions, physical memory location, pitch, alignment, etc. with respect to the specific operations performed on the objects.

Unsigned Normalized (UNORM)

An unsigned normalized value with n bits is interpreted as a value between 0.0 and 1.0. The minimum value (all 0's) is interpreted as 0.0, the maximum value (all 1's) is interpreted as 1.0. Values in between are equally spaced. For example, a 2-bit UNORM value would have the four values 0, 1/3, 2/3, and 1.

If the incoming value is interpreted as an n -bit integer, the interpreted value can be calculated by dividing the integer by $2^n - 1$.

Gamma Conversion (SRGB)

Gamma conversion is only supported on UNORM formats. If this flag is included in the surface format name, it indicates that a reverse gamma conversion is to be done after the source surface is read, and a forward gamma conversion is to be done before the destination surface is written.

Signed Normalized (SNORM)

Programming Note	
Context:	Signed normalized value in memory data formats.
A signed normalized value with n bits is interpreted as a value between -1 and +1.0. If the incoming value is interpreted as a 2's-complement n -bit integer, the interpreted value can be calculated by dividing the integer by $2^{n-1} - 1$. The most negative value of -2^{n-1} will result in a value slightly smaller than -1.0. This value is clamped to -1.0; thus, there are two representations of -1.0 in SNORM format.	

Unsigned Integer (UINT/USCALED)

The UINT and USCALED formats interpret the source as an unsigned integer value with n bits with a range of 0 to $2^n - 1$.

The UINT formats copy the source value to the destination (zero-extending if required), keeping the value as an integer.

The USCALED formats convert the integer into the corresponding floating point value (e.g., 0x03 --> 3.0f). For 32-bit sources, the value is rounded to nearest even.

Signed Integer (SINT/SSCALED)

A signed integer value with n bits is interpreted as a 2's complement integer with a range of -2^{n-1} to $+2^{n-1} - 1$.

The SINT formats copy the source value to the destination (sign-extending if required), keeping the value as an integer.

The SSCALED formats convert the integer into the corresponding floating point value (e.g., 0xFFFFD --> -3.0f). For 32-bit sources, the value is rounded to nearest even.

Floating Point (FLOAT)

Refer to IEEE Standard 754 for Binary Floating-Point Arithmetic. The IA-32 Intel (R) Architecture Software Developer’s Manual also describes floating point data types.

64-bit Floating Point

Bit	Description
63	Sign (s)
62:52	Exponent (e) Biased Exponent
51:0	Fraction (f) Does not include “hidden one”

The value of this data type is derived as:

- if $e == b'11..11'$ and $f != 0$, then v is NaN regardless of s
- if $e == b'11..11'$ and $f == 0$, then $v = (-1)^s * \text{infinity}$ (signed infinity)
- if $0 < e < b'11..11'$, then $v = (-1)^s * 2^{(e-1023)} * (1.f)$
- if $e == 0$ and $f != 0$, then $v = (-1)^s * 2^{(e-1022)} * (0.f)$ (denormalized numbers)
- if $e == 0$ and $f == 0$, then $v = (-1)^s * 0$ (signed zero)

32-bit Floating Point

Bit	Description
31	Sign (s)
30:23	Exponent (e) Biased Exponent
22:0	Fraction (f) Does not include “hidden one”

The value of this data type is derived as:

- if $e == 255$ and $f != 0$, then v is NaN regardless of s
- if $e == 255$ and $f == 0$, then $v = (-1)^s * \text{infinity}$ (signed infinity)
- if $0 < e < 255$, then $v = (-1)^s * 2^{(e-127)} * (1.f)$
- if $e == 0$ and $f != 0$, then $v = (-1)^s * 2^{(e-126)} * (0.f)$ (denormalized numbers)
- if $e == 0$ and $f == 0$, then $v = (-1)^s * 0$ (signed zero)

16-bit Floating Point

Bit	Description
15	Sign (s)
14:10	Exponent (e) Biased Exponent
9:0	Fraction (f) Does not include "hidden one"

The value of this data type is derived as:

- if $e == 31$ and $f != 0$, then v is NaN regardless of s
- if $e == 31$ and $f == 0$, then $v = (-1)^s * \text{infinity}$ (signed infinity)
- if $0 < e < 31$, then $v = (-1)^s * 2^{(e-15)} * (1.f)$
- if $e == 0$ and $f != 0$, then $v = (-1)^s * 2^{(e-14)} * (0.f)$ (denormalized numbers)
- if $e == 0$ and $f == 0$, then $v = (-1)^s * 0$ (signed zero)

The following table represents relationship between 32 bit and 16 bit floating point ranges:

flt32 exponent	Unbiased exponent	Underflow method/ Sign bit	flt16 exponent	flt16 fraction
255				
254	127			
...				
127+16	16	Infinity	31	1.1111111111
127+15	15	Max exponent	30	1.xxxxxxxxxx
127	0		15	1.xxxxxxxxxx
113	-14	Min exponent	1	1.xxxxxxxxxx
112		Denormalized	0	0.1xxxxxxxxx
111		Denormalized	0	0.01xxxxxxxxx
110		Denormalized	0	0.001xxxxxxxxx
109		Denormalized	0	0.0001xxxxxxxxx
108		Denormalized	0	0.00001xxxxxx
107		Denormalized	0	0.000001xxxxx
106		Denormalized	0	0.0000001xxx
115		Denormalized	0	0.00000001xx
114		Denormalized	0	0.000000001x
113		Denormalized	0	0.0000000001
112		Denormalized	0	0.0
...				
0			0	0.0

Conversion from the 32-bit floating point format to the 16-bit format should be done with round to nearest even.

11-bit Floating Point

Bits	Description
10:6	Exponent (e): Biased exponent (the bias depends on e)
5:0	Fraction (f): Fraction bits to the right of the binary point

The value v of an 11-bit floating-point number is calculated from e and f as:

- if $e == 31$ and $f != 0$ then $v = \text{NaN}$
- if $e == 31$ and $f == 0$ then $v = +\text{infinity}$
- if $0 < e < 31$, then $v = 2^{(e-15)} * (1.f)$
- if $e == 0$ and $f != 0$, then $v = 2^{(e-14)} * (0.f)$ (denormalized numbers)
- if $e == 0$ and $f == 0$, then $v = 0$ (zero)

There is no sign bit and negative values are not represented.

The 11-bit floating-point format has one more bit of fractional precision than the 10-bit floating-point format.

The maximum representable finite value is $1.111111b * 2^{15} = \text{FE00h} = 65024$.

10-bit Floating Point

Bits	Description
9:5	Exponent (e): Biased exponent (the bias depends on e)
4:0	Fraction (f): Fraction bits to the right of the binary point

The value v of a 10-bit floating-point number is calculated from e and f as:

- if $e == 31$ and $f != 0$ then $v = \text{NaN}$
- if $e == 31$ and $f == 0$ then $v = +\text{infinity}$
- if $0 < e < 31$, then $v = 2^{(e-15)} * (1.f)$
- if $e == 0$ and $f != 0$, then $v = 2^{(e-14)} * (0.f)$ (denormalized numbers)
- if $e == 0$ and $f == 0$, then $v = 0$ (zero)

There is no sign bit and negative values are not represented.

The maximum representable finite value is $1.111111b * 2^{15} = \text{FC00h} = 64512$.

Shared Exponent

The R9G9B9E5_SHAREDEXP format contains three channels that share an exponent. The three fractions assume an implied "0" rather than an implied "1" as in the other floating point formats. This format does not support infinity and NaN values. There are no sign bits, only positive numbers and zero can be represented. The value of each channel is determined as follows, where "f" is the fraction of the corresponding channel, and "e" is the shared exponent.

$$v = (0.f) * 2^{(e-15)}$$

Bit	Description
31:27	Exponent (e) Biased Exponent
26:18	Blue Fraction
17:9	Green Fraction
8:0	Red Fraction